

Remote 2/1GN COUNTER

GENERAL FEATURES

- Ext & int 304 S/S ; Back and base galvanized
- Anti-condensation door mullion heaters
- Remote condensing unit
- Forced air cooling system
- Hygienic one-piece S/S dished base with round corners
- Removable door gasket ; Digital smart controller
- Adjustable PE coated shelves; Accommodates with 2/1GN size
- Self-vaporizing system, no need drainage connect
- Environmental friendly refrigerant; CFC-free insulation
- High density insulation foam 43 kg/m³
- Integrated bending handle
- Less 90° self closing door, over 90° door opening
- Adjustable legs or castors (Optional)
- Cylindrical door locks
- Designed to operate up to 43 C

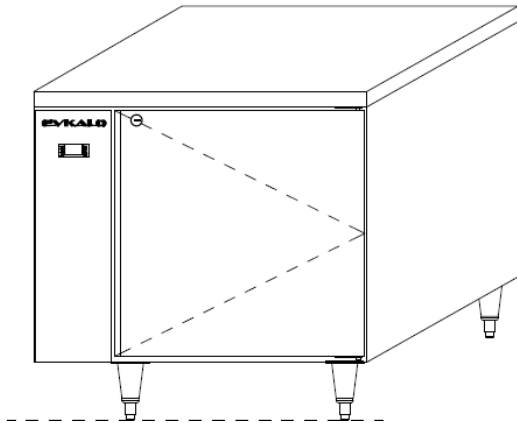

MODEL						
	HCR2G1DR	LCR2G1DR	HCR2G1NR	LCR2G1NR	HCR2G1WR	LCR2G1WR
Temp(°C)	+1 / +4°C	-22 / -18°C	+1 / +4°C	-22 / -18°C	+1 / +4°C	-22 / -18°C
Dimension	860x770x850					
Power (W)	1100	1540	1100	1540	1100	1540
Voltage	220V / 50Hz / 1PH					
Capacity (L)	214					
Refrigerant	R134a	R404a	R134a	R404a	R134a	R404a
Defrost	Off cycle	Electric	Off cycle	Electric	Off cycle	Electric

Important Notes:

- * All refrigeration equipment requires adequate ventilation for efficient performance.
- * Kalo reserve the right to change product specifications stated without prior notice.

