

Remote 1/1GN COUNTER

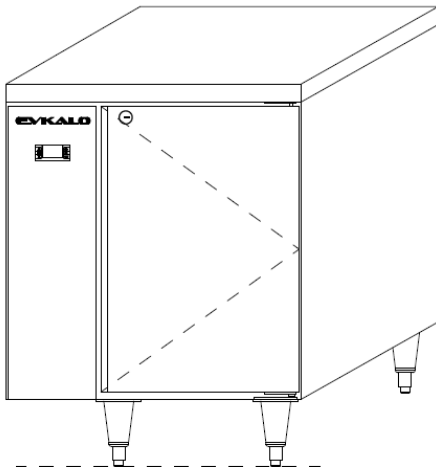

GENERAL FEATURES

- Ext & int 304 S/S ; Back and base galvanized
- Anti-condensation door mullion heaters
- Remote condensing unit
- Forced air cooling system
- Hygienic one-piece S/S dished base with round corners
- Removable door gasket ; Digital smart controller
- Adjustable PE coated shelves; Accommodates with 1/1GN size
- Self-vaporizing system, no need drainage connect
- Environmental friendly refrigerant; CFC-free insulation
- High density insulation foam 43 kg/m³
- Integrated bending handle
- Less 90° self closing door, over 90° door opening
- Adjustable legs or castors (Optional)
- Cylindrical door locks
- Designed to operate up to 43 C

MODEL						
	HCR1G1DR	LCR1G1DR	HCR1G1NR	LCR1G1NR	HCR1G1WR	LCR1G1WR
Temp(°C)	+1 / +4°C	-22 / -18°C	+1 / +4°C	-22 / -18°C	+1 / +4°C	-22 / -18°C
Dimension	655x670x850					
Power (W)	660	880	660	880	660	880
Voltage	220V / 50Hz / 1PH					
Capacity (L)	116					
Refrigerant	R134a	R404a	R134a	R404a	R134a	R404a
Defrost	Off cycle	Electric	Off cycle	Electric	Off cycle	Electric

Important Notes:

- * All refrigeration equipment requires adequate ventilation for efficient performance.
- * Kalo reserve the right to change product specifications stated without prior notice.

Dongguan Kalo Refrigeration Co.,LTD
 Sanxing Road, Tiesong Management Area,
 Qingxi, Dongguan China 523642

T: +86 769 87282033
 E: sales1@kalo-china.com
 www.kalo-china.com

